

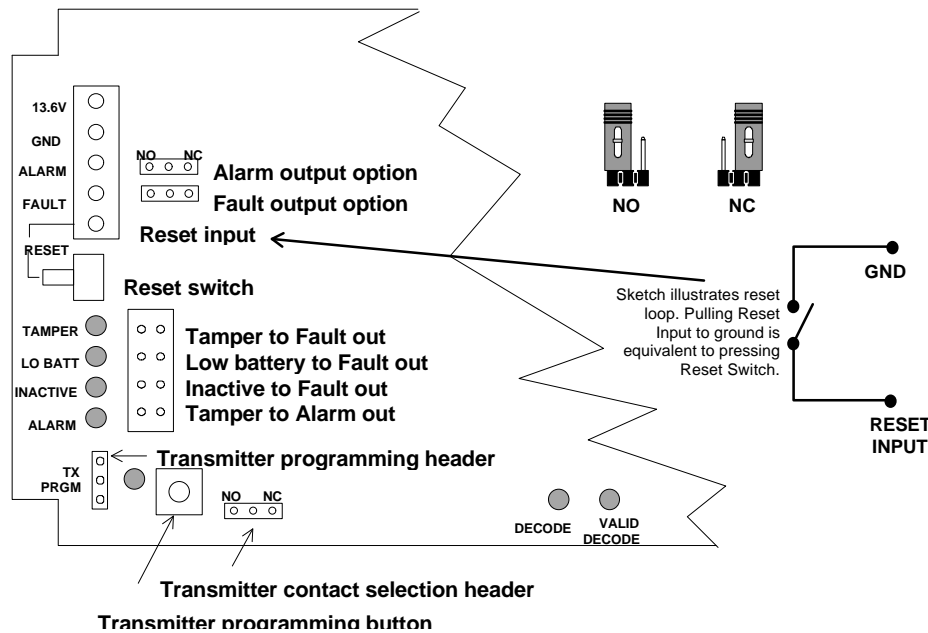

**Overview:** The FA401 fully supervises a single wireless point. Alarm and fault outputs can be Normally Open or Normally Closed. Fault conditions are selectable. Program any FA-series Inovonics transmitter by connecting the transmitter to the receiver.



### Program the Transmitter:

- 1) Select Normally Open (NO) or Normally Closed (NC) contact by placing a jumper on the 3-pin TRANSMITTER CONTACT SELECTION HEADER.
- 2) Plug programming cable to 3-pin TRANSMITTER PROGRAMMING HEADER on the receiver. Orientation of the cable connector to the header pins makes no difference.
- 3) Press the TRANSMITTER PROGRAMMING BUTTON on the receiver. It is located next to the TRANSMITTER PROGRAMMING HEADER. The receiver goes into program mode. It exits when the transmitter is programmed (Step 7) or after 30 seconds.
- 4) The inactive LED, decode LED and valid decode LED will light and stay on during program mode.
- 5) Connect the programming cable to 3-pin header on transmitter. Orientation of the connector to header pins does not matter.
- 6) Press the TRANSMITTER RESET BUTTON.
- 7) If programming is successful, program mode will terminate: the inactive LED will go out immediately and the decode and valid decode LEDs will resume normal operation.

Note: The decode LED indicates RF activity in the FA401's frequency range. The valid decode LED indicates transmissions from any FA-series transmitter. The receiver will identify and process data from the transmitter specifically programmed to it.)

**Warning: The FA401 receiver supports only one transmitter.** Each time a transmitter is programmed a new system ID is generated. Transmitters previously programmed will no longer be recognized.

Note: The FA401 will **not** support FA200W or FA210W widegap magnet contacts.

**Power the Receiver:** Apply power and ground to marked terminals.

**Select Normally Open or Normally Closed Alarm and Fault output options:** Place 2-pin jumpers on headers beside output terminals to select Normally Open (NO) or Normally Closed (NC) output.

**Select supervision options:** Place jumpers on header blocks beside LED indicators to select fault conditions .

Select TAMPER, LO BATT and/or INACTIVE to have these respective trouble conditions activate the FAULT output. To cause tamper conditions to activate the alarm output, select the ALARM option. (Can be used with or without TAMPER option.)

The FA401 receiver is programmed with the following pre-selected, fixed parameters: 60-minute supervisory window, ALARM and INACTIVE supervisory outputs are configured to follow transmitter conditions, TAMPER and LO BATT are configured to latch.

**Note:** Latched faults may be reset by pressing the RESET switch or by pulling the RESET input to ground.

# Warranty & Disclaimer

## Specifications:

Housing Size:	5.75 x 3.60 x 1.25 inches
Power Requirement:	11 to 14 VDC
Weight:	7 oz
Type:	900 MHz Frequency Agile™ (Spread Spectrum)
FCC #:	HCQ3B6SSR1
Output voltage change:	from 13.6VDC to 0.1VDC on N/O activation

The transmitter is programmed with the following fixed parameters:

- No EOL resistor.
- 60-second supervisory check-in. (The transmitter sends a supervisory signal every 60 seconds. The receiver, with a fixed 60-minute supervisory window, will declare the point inactive if no supervisory signal is received within 1 hour of the latest signal.)
- No Internal Contact. (The receiver does not support the FA200W or FA210W widegap magnet contacts.)

Note: FA transmitters have non-volatile memory. It is not necessary to reprogram transmitters after losing power or changing batteries. Press the transmitter reset button to restore programming.

Inovonics Corporation ("Inovonics") warrants its products ("Product" or "Products") to conform to its own specifications and to be free of defects in materials and workmanship under normal use for a period of twenty-four (24) months from the date of manufacture. Within the warranty period Inovonics Corporation will repair or replace, at its option, all or any part of the warranted product. Inovonics will not be responsible for dismantling and/or reinstallation charges. To exercise the warranty, the User ("User", "Installer" or "Consumer") must be given a Return Material Authorization ("RMA") Number by Inovonics. Details of shipment will be arranged at that time.

This warranty does not apply in cases of improper installation, misuse, failure to follow installation and operating instructions, alteration, abuse, accident or tampering, and repair by anyone other than Inovonics.

This warranty is exclusive and expressly in lieu of all other warranties, obligations or liabilities, whether written, oral, express, or implied, including any warranty of merchantability or fitness for a particular purpose. Inovonics will not be liable to anyone for any consequential or incidental damages for breach of this warranty or any other warranties.

This warranty will not be modified, varied or extended. Inovonics does not authorize any person to act on its behalf to modify, vary or extend this warranty. This warranty will apply to Inovonics Products only. All other products, accessories or attachments used in conjunction with Inovonics equipment, including batteries, will be covered solely by their own warranty, if any. Inovonics will not be liable for any direct, incidental or consequential damage or loss whatsoever, caused by the malfunction of Product due to products, accessories, or attachments of other manufacturers, including batteries, used in conjunction with Inovonics Products.

This warranty does not warrant the replacement of batteries that are used to power Inovonics Products.

**Continued on next page.**

## Warranty & Disclaimer (continued)

The User recognizes that a properly installed and maintained security system may only reduce the risk of events such as burglary, robbery, personal injury and fire. It does not insure or guarantee that there will be no death, personal damage and/or damage to property as a result.

**Inovonics does not claim that the Product may not be compromised and/or circumvented, or that the Product will prevent any death, personal and/or bodily injury and/or damage to property resulting from burglary, robbery, fire or otherwise, or that the Product will in all cases provide adequate warning or protection.**

**Inovonics Corporation shall have no liability for any death, injury or damage, however incurred, based on a claim that Inovonics Products failed to function.** However, if Inovonics is held liable, directly or indirectly, for any loss or damage arising under this limited warranty or otherwise, regardless of cause or origin, Inovonics' maximum liability will not in any case exceed the purchase price of the Product, which will be fixed as liquidated damages and not as a penalty, and will be the complete and exclusive remedy against Inovonics.

**Warning:** **The User should follow all installation, operation and maintenance instructions.** The User is strongly advised to conduct Product and systems tests at least once each week. Changes in environmental conditions, electric or electronic disruptions and tampering, may cause the Product to not perform as expected.



**Warning:** **Inovonics warrants its Product to the User.** The User is responsible for exercising all due prudence and taking necessary precautions for the safety and protection of lives and property wherever Inovonics Products are installed. Inovonics strongly advises the User to program Products to be supervised whenever used in applications affecting life safety. Users are warned that unsupervised devices are subject to undetected failure due to malfunction, battery failure, tampering, or changes in environment.



**Inovonics** Corporation  
2100 Central Avenue  
Boulder CO 80301  
Phone: (800) 782-2709  
FAX: (303) 939-8977  
BBS: (303) 939-9701  
E-Mail: support@inovonics.com

